

MPLO20-D6C-B4T1

Features

- ◆ Single fiber quad-directional data link
- ◆ XGSPON/XGPON: 9.953Gbps downstream and 9.953Gbps/2.488Gbps upstream
- ◆ GPON: 2.488Gbps downstream and 1.244Gbps upstream
- ◆ XGSPON/XGPON: 1577nm continuous-mode EML laser transmitter and 1270nm burst-mode APD-TIA receiver
- ◆ GPON: 1490nm continuous-mode DFB laser transmitter and 1310nm burst-mode APD-TIA receiver
- ◆ 0 to +70°C operating case temperature
- ◆ +3.3V power supply
- ◆ SFP+ package with SC/UPC Receptacle connector
- ◆ 2-wire interface for integrated Digital Diagnostic Monitoring
- ◆ Digital Receiving Signal Strength Indication (RSSI)
- ◆ Low EMI and excellent ESD protection
- ◆ Class1 laser safety standard IEC-60825 compliant
- ◆ RoHS compliance

Application

- ◆ XGSPON OLT (N1 class ODN)
- ◆ XGPON OLT (N1 class ODN)
- ◆ GPON OLT (class B+)

Standard

- ◆ Complies with SFF-8431/SFF-8432
- ◆ Complies with SFF-8472
- ◆ Complies with ITU-T G.987.2 & G.9807.1 & G.984.2
- ◆ Complies with FCC 47 CFR Part 15, Class B
- ◆ Complies with FDA 21 CFR 1040.10 and 1040.11 except for deviations pursuant to Laser Notice No. 50, dated June 24, 2007

Description

The MPLO20-D6C-B4T1 is a Combo OLT optical transceiver designed to compact XGSPON/XGPON and GPON applications. For XGSPON/XGPON, it employs a 1577nm EML CW mode downstream transmitter operating at 9.953Gbps and a 1270nm APD/TIA burst mode upstream receiver operating at 9.953Gbps or 2.488Gbps. For GPON, it employs a 1490nm DFB CW mode downstream transmitter operating at 2.488Gbps and a 1310nm APD/TIA burst mode upstream receiver operating at 1.244Gbps. It is housed in SFP+ package and is designed to operate over the commercial temperature range from 0 to +70°C.

Specification

Absolute Maximum Ratings				
Parameter	Symbol	Min	Max	Unit
Storage temperature	Ts	-40	+85	°C
Storage Relative Humidity	RH _s	5	90	%
Operating Relative Humidity	RH _o	5	85	%
Power Supply Voltage	Vcc	0	+3.6	V

Recommended Operating Conditions					
Parameter	Symbol	Min	Typical	Max	Unit
Operating Case Temperature	Tc	0		+70	°C
Power Supply Voltage	V _{CC3}	3.135	3.3	3.465	V
Supply Current	I _{CC3}			1000	mA
Power Consumption	P _w			3.5	W
Data Rate	XGSPON/ XGPON		TX 9.953 RX 9.953/2.488		Gbps
	GPON		TX 2.488 RX 1.244		

Electrical Characteristics						
Parameter	Symbol	Min	Typical	Max	Unit	Notes
Transmitter Differential Data Input Swing	V _{INPP}	120		800	mV	XGSPON/XGPON
		200		1600	mV	GPON
Transmitter Differential Input Impedance	Z _{IN}		100		Ω	
Receiver Differential Data Output Swing	V _{OUTPP}	400		800	mV	XGSPON/XGPON
		600		1600	mV	GPON

Receiver Differential Output Impedance	Z _{OUT}	80	100	120	Ω	
TX Disable	V _{TDH}	2.0		V _{CC}	V	LVTTTL input
	V _{TDL}	0		0.8		
TX Fault	V _{TFH}	2.4		V _{CC}	V	LVTTTL output
	V _{TFL}	0		0.4		
RX Reset	V _{RSTH}	2.0		V _{CC}	V	LVTTTL input
	V _{RSTL}	0		0.8		
RX_SD	V _{SDH}	2.4		V _{CC}	V	LVTTTL output
	V _{SDL}	0		0.4		

Optical transmitter Characteristics							
Parameter		Symbol	Min	Typical	Max	Unit	Notes
Operating Wavelength Range	XGSPON/ XGPON	λc1	1575		1580	nm	
	GPON	λc2	1480	1490	1500	nm	
Launched Power	XGSPON/ XGPON	P _{OUT1}	+2		+5	dBm	
	GPON	P _{OUT2}	+1.5		+5	dBm	
Spectral Width(-20dB)		Δλ			1	nm	
Side Mode Suppression Mode		SMSR	30			dB	
Extinction Ratio		ER	8.2			dB	
Optical Output Power after TX Disable		P _{OFF}			-39	dBm	
Transmitter tolerance to reflected optical power			-15			dB	
Output Eye Diagram		XGSPON XGPON	Compliant with ITU-T G.9807.1 and ITU-T G.987.2				Figure 1
		GPON	Compliant with ITU-T G.984.2				
Optical receiver Characteristics							
Parameter		Symbol	Min	Typical	Max	Unit	Notes
Operating Wavelength Range	XGSPON/ XGPON	λc3	1260	1270	1280	nm	
	GPON	λc4	1290	1310	1330	nm	

Receiver Sensitivity	XGSPON	P _{SEN1}			-26	dBm	BER < 10 ⁻³
	XGPON	P _{SEN2}			-27.5	dBm	BER < 10 ⁻⁴
	GPON	P _{SEN3}			-28	dBm	BER < 10 ⁻¹⁰
Saturation Optical Power	XGSPON	P _{SAT1}	-5			dBm	
	XGPON	P _{SAT2}	-7			dBm	
	GPON	P _{SAT3}	-8			dBm	
Immunity from Continuous Identical Digits		CID	72			Bit	
Receiver Reflectance					-20	dB	
Tolerance to the reflected optical power					10	dB	

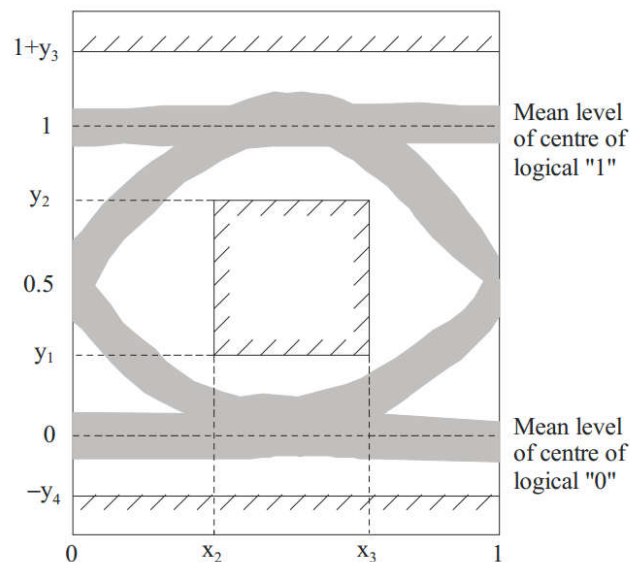

Note: The X2 and X3 of the rectangular eye mask need not be equidistant with respect to the vertical axes at 0 UI and 1 UI.

	2.488Gbps	9.953Gbps
X3-X2	0.2	0.2
Y1	0.25	0.25
Y2	0.75	0.75
Y3	0.25	0.25
Y4	0.25	0.25

Figure 1 XGSPON/XGPON&GPON Transmitter Eye Mask Definitions

Receiver Timing Characteristics							
Parameter		Symbol	Min.	Typ.	Max.	Unit	Notes
Guard Time	XGSPON	Tg	64			Byte	
	XGPON		8				
	GPON		4				
10G Reset Pulse Width		Tr	25.6			ns	
1.25G Reset Pulse Width			12.8				
Data Recovery Time		Tsettle			24	ns	
SD Assert Time		Ta			25	ns	
SD De-assert Time		Td			25	ns	

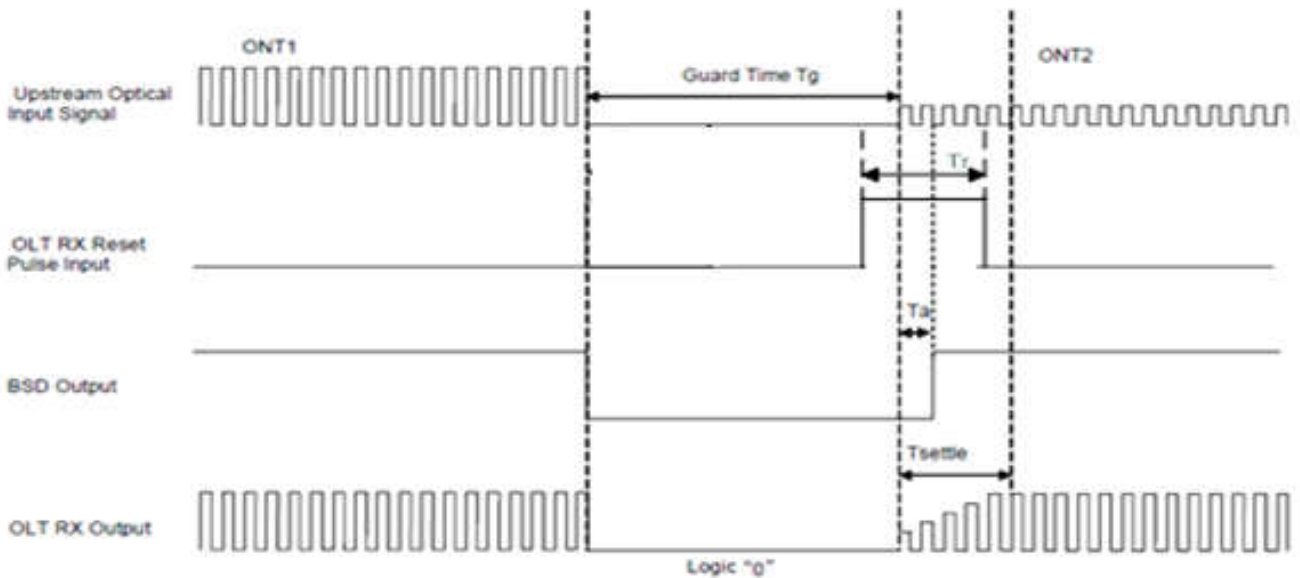

Figure 2 Timing Parameter Definitions in Burst Mode Sequence a

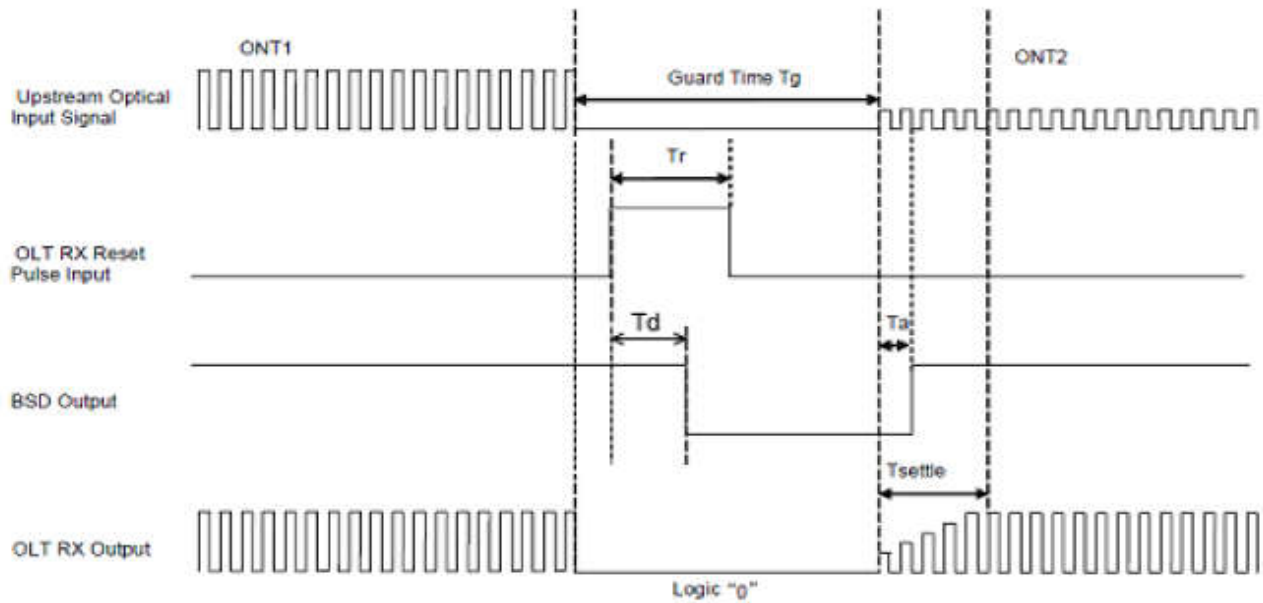

Figure 3 Timing Parameter Definitions in Burst Mode Sequence b

RSSI Characteristics						
Parameter	Symbol	Min.	Typ.	Max.	Unit	Notes
RSSI Trigger-Low		0		0.8	V	
RSSI Trigger-High		2.0		V_{CC}	V	
RSSI Trigger Delay	T_D	100	300		ns	
Optical Signal During Time	T_{ONT}	1			us	
RSSI Trigger width	T_W	300		$T_{ONT}-T_D$	ns	
I2C Access Prohibited Time	T_p	500			μ s	
RSSI monitoring range	Pmon	-5		-26.5	dBm	XGSPON
		-5		-27.5		XGPON
		-8		-28		GPON

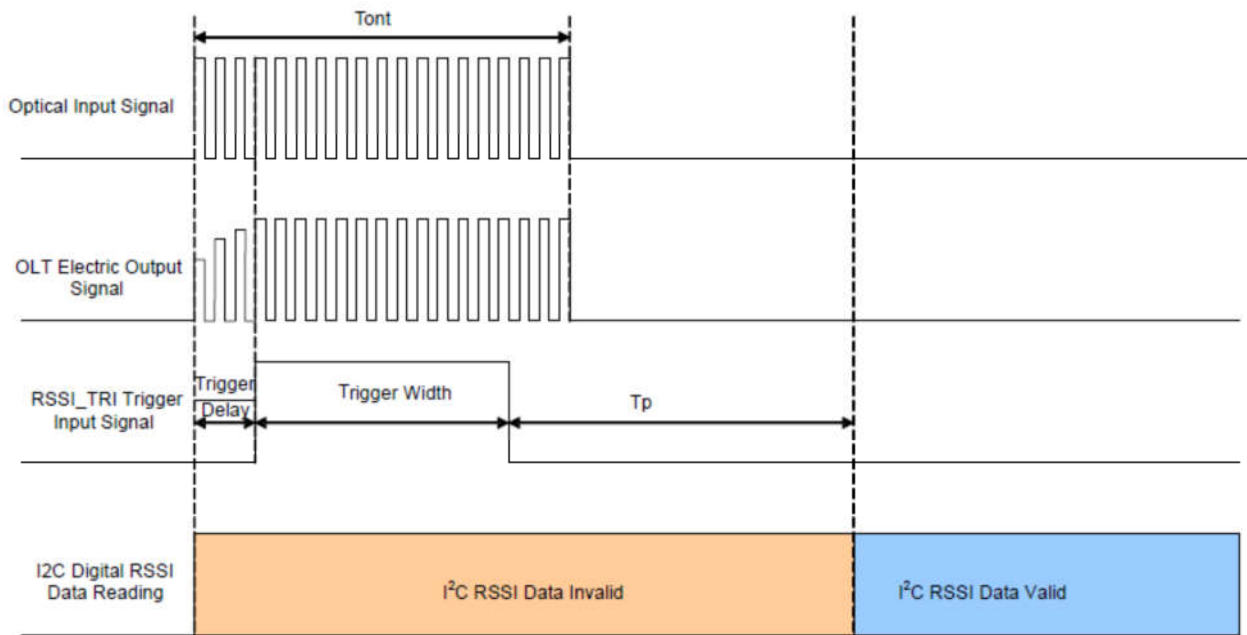

Figure 4 Timing Parameter Definitions in RSSI Trigger

Digital Diagnostic Monitoring Information

Parameter	Accuracy	Calibration	Unit	
Temperature	±3	Internal	℃	
Voltage	±3%	Internal	V	
Bias Current	±10%	Internal	mA	Quantization Unit 4uA
TX Power	±2	Internal	dBm	Quantization Unit 0.2μW
RX Power	±2	Internal	dBm	Quantization Unit 0.1μW

Note: The digital diagnostic monitoring interface defines 256-byte memory map in EEPROM, which makes use of the 8 bit address 1010001X(A2h) and 1011001X(B2h), respectively. Please refer to the SFF-8472 for the detail information.

Pin Definition

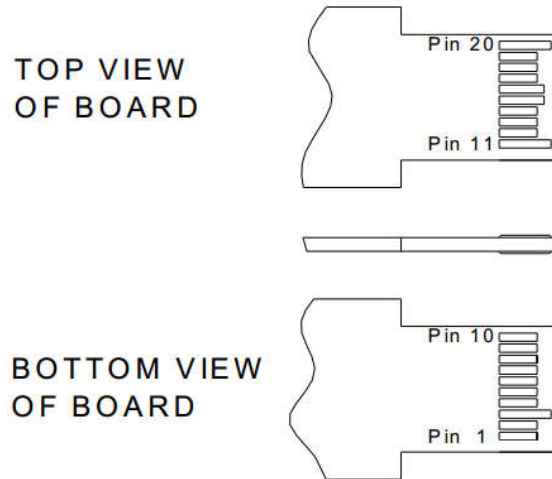
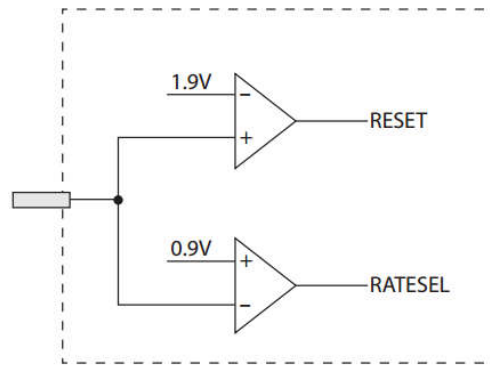

Figure 5 Pin out Drawing

Pin No	Name	Default Description	Note
1	GPON_TD+	Non-Inverted 2.488Gbps Transmit Data input	AC coupled
2	GPON_TD-	Inverted 2.488Gbps Transmit Data input	AC coupled
3	GND	Module Ground	
4	SDA	2-Wire Serial Interface data line	LVTTTL
5	SCL	2-Wire Serial Interface clock line	LVTTTL
6	GPON_RD-	Inverted 1.25Gps RX Data Output	LVPECL, DC coupled
7	XGSPON_RST/RateSel	Burst Mode Module Reset Signal and Rate Select Signal	Tri-level Input
8	XGSPON/XGPON_SD	High: normal; Low: loss of signal	LVTTTL Output
9	TRIG/TXDIS	RSSI Trigger/TX_Disable	LVTTTL Input
10	GPON_RD+	Non-inverted 1.25Gps RX Data Output	LVPECL, DC coupled
11	GND	Module Ground	
12	XGSPON/XGPON_RD-	Inverted 9.953Gps RX Data Output	CML, DC coupled
13	XGSPON/XGPON_RD+	Non-inverted 9.953Gps RX Data Output	CML, DC coupled
14	GPON_SD	High: normal; Low: loss of signal	LVTTTL Output
15	VCC3_RX	Receiver 3.3V Power Supply	
16	VCC3_TX	Transmitter 3.3V Power Supply	
17	GPON_RST	GPON RX Reset	LVTTTL Input
18	XGSPON/XGPON_TD+	Non-Inverted 9.953Gbps Transmit Data input	CML, AC coupled
19	XGSPON/XGPON_TD-	Inverted 9.953Gbps Transmit Data input	CML, AC coupled
20	GND	Module Ground	

3-Level Combined Reset/Rate Select

Pin-7(XGSPON_RST/RateSel) supports either single Reset signal or a 3-level signal which combines the Reset and Rate Select signals. The logic, recommended sequence and truth table of 3-level signal is as shown below:



3-level signaling logic

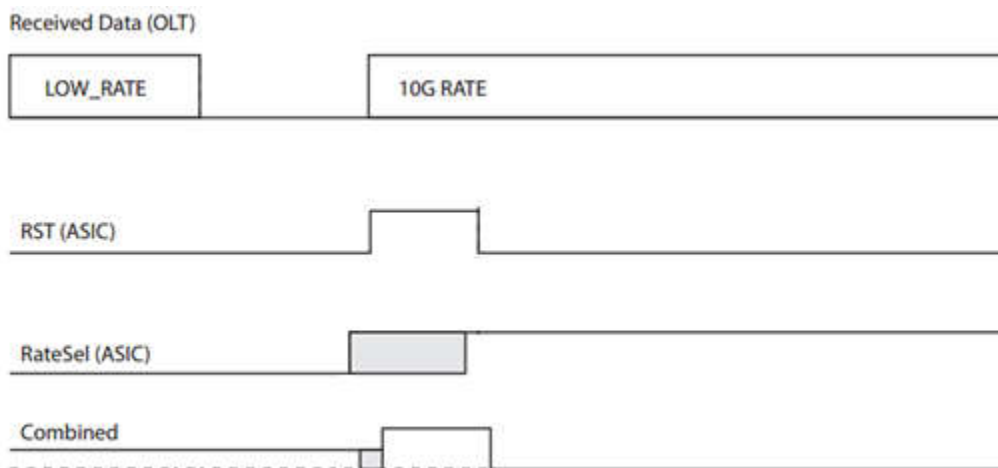

3-level signaling recommended sequence

RATESEL/RESET	RateSel	RESET
H	10	1
M	2.5	0
L	10	0

3-level signaling truth table

Functional Diagram

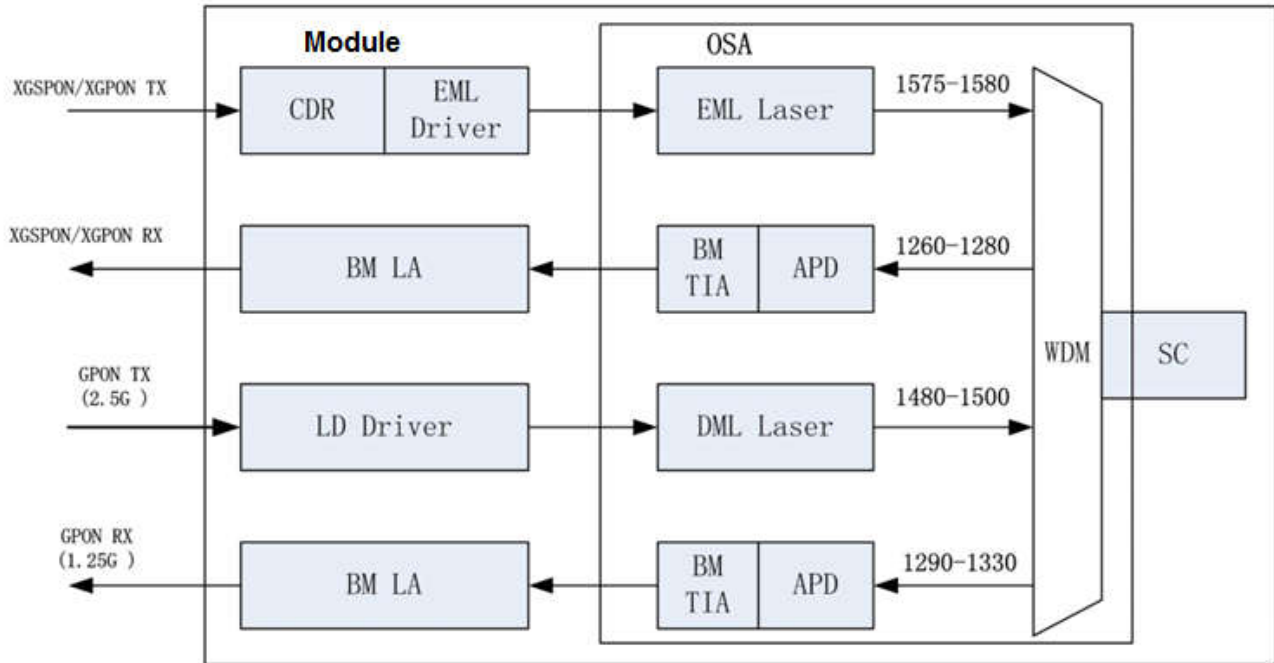

Figure 6 MPLO20-D6C-B4T1 functional diagram

2-Wire Serial Memory Map

Memory map for SFP+ XGSPON&GPON Combo OLT is illustrated in Figure 6. A0h(1010000X) and B0h(1011000X) are the Serial ID addresses for XGSPON/XGPON and GPON OLT, respectively. A2h(1010001X) and B2h(1011001X) are the Digital Diagnostic addresses for XGSPON/XGPON and GPON OLT, respectively.

Contents of Serial ID of XGSPON/XGPON and GPON OLT are defined in 2-Wire Address A0h/B0h. Contents of Digital Diagnostics Memory of XGSPON/XGPON and GPON OLT are defined in 2-Wire Address A2h/B2h. Both of XGSPON/XGPON and GPON OLT are compatible with SFF-8472.

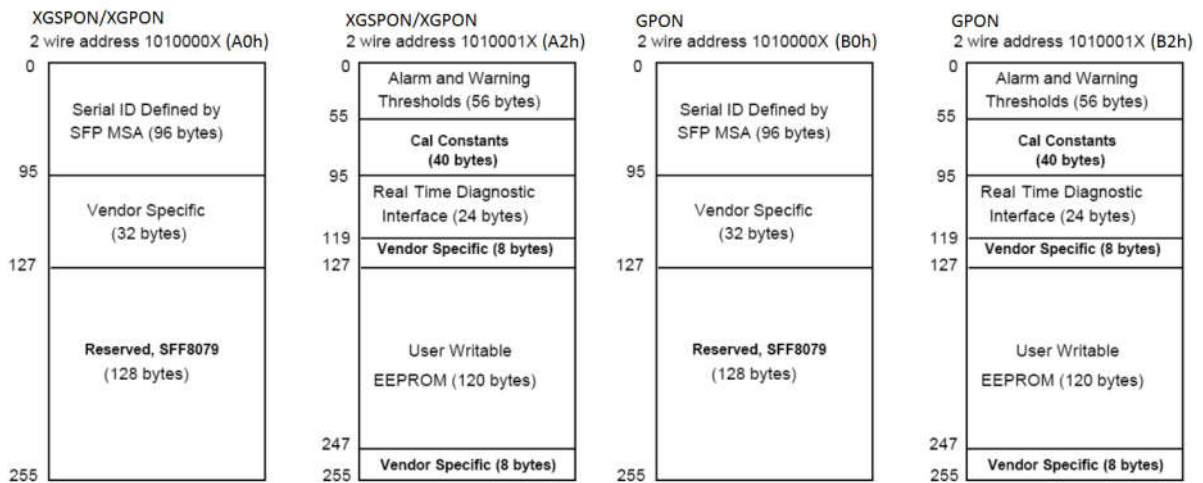

Figure 7 EEPROM Memory Map Specific Data Field Descriptions

EEPROM Serial ID Memory Contents

The optical transceiver contains an EEPROM. It provides access to sophisticated identification information that describes the transceiver’s capabilities, standard interfaces, manufacturer, and other information. When the serial protocol is activated, the host generates the serial clock signal (SCL). The positive edge clocks data into those segments of the EEPROM that are not writing protected within the SFP transceiver. The negative edge clocks data from the SFP+ transceiver. The serial data signal (SDA) is bi-directional for serial data transfer. The host uses SDA in conjunction with SCL to mark the start and end of serial protocol activation. The memories are organized as a series of 8-bit data words that can be addressed individually or sequentially.

The Module provides diagnostic information about the present operating conditions. The transceiver generates this diagnostic data by digitization of internal analog signals. Calibration and alarm/warning threshold data is written during device manufacture. Received power monitoring, transmitted power monitoring, bias current monitoring, supply voltage monitoring and temperature monitoring all are implemented. The diagnostic data are raw A/D values and must be converted to real world units using calibration constants stored in EEPROM locations 56 – 95 at wire serial bus address A2h/B2h. The digital diagnostic memory map specific data fields define as following.

EEPROM serial ID memory contents (XGSPON/XGPON A0h)

Address	#Bytes	Name	HEX	Description
0	1	Identifier	03	SFP+
1	1	Ext. Identifier	04	Non Standard GBIC Interface
2	1	Connector	01	SC connector
3-10	8	Transceiver	00 0000 00 00 00 00 00	Code for electronic compatibility or optical compatibility
11	1	Encoding	03	NRZ
12	1	BR, Nominal	64	10Gbps
13	1	Reserved	00	Reserved
14	1	Length(9μm)-km	14	20km
15	1	Length(9μm)-100m	C8	20km
16	1	Length (50μm OM2)-10m	00	Not Supported
17	1	Length (62.5μm OM1)-10m	00	Not Supported
18	1	Length (Copper)	00	Not Supported
19	1	Length (50μm OM3)-10m	00	Not Supported
20-35	16	Vendor name	4D 45 4E 54 45 43 48 4F 50 54 4F 20 20 20 20 20	"MENTECHOPTO"(ASCII character)
36	1	Reserved	00	Reserved
37-39	3	Vendor OUI	00 00 00	No specific
40-55	16	Vendor PN	4D 50 4C 4F 32 30 2D 44 36 43 2D 43 33 44 54 31	MPLO20-D6C-B4T1
56-59	4	Vendor rev	41 30 20 20	A0
60-61	2	Wavelength	06 29	1577nm
62	1	Reserved	00	Reserved
63	1	CC_BASE	Programmed by Factory	Check sum of bytes 0-62
64-65	2	Transceiver Options	14	page selection, Cooled LD
			14	RX_SD, TX_Disable
66	1	BR, max	00	
67	1	BR, min	00	
68-83	16	Vendor SN	Programmed by Factory	Serial number provided by vendor (ASCII)
84-91	8	Date Code	"YYMMDDLL"	Vendor's manufacturing date code (ASCII)

92	1	Diagnostic Monitoring Type	68	Internal Calibrated; Received power measurement type: Average Power
93	1	Enhanced Options	E0	Optional Alarm/warning implemented; Soft TX_DISABLE, TX_FAULT implemented
94	1	Compliance	08	Revision Implemented
95	1	CC_EXT	Programmed by Factory	Check sum of bytes 64-94
96-127	32	Vendor Specific		Vendor Specific EEPROM
128-255	128	Reserved	00	Reserved

EEPROM serial ID memory contents (GPON B0h)

Address	#Bytes	Name	HEX	Description
0	1	Identifier	03	SFP+
1	1	Ext. Identifier	04	Non Standard GBIC Interface
2	1	Connector	01	SC connector
3-10	8	Transceiver	00 00 00 00 00 00 00 00	Code for electronic compatibility or optical compatibility
11	1	Encoding	03	NRZ
12	1	BR, Nominal	19	2.488Gbps
13	1	Reserved	00	Reserved
14	1	Length(9μm)-km	14	20km
15	1	Length(9μm)-100m	C8	20km
16	1	Length (50μm OM2)-10m	00	Not Supported
17	1	Length (62.5μm OM1)-10m	00	Not Supported
18	1	Length (Copper)	00	Not Supported
19	1	Length (50μm OM3)-10m	00	Not Supported
20-35	16	Vendor name	4D 45 4E 54 45 43 48 4F 50 54 4F 20 20 20 20 20	"MENTECHOPTO"(ASCII character)
36	1	Reserved	00	Reserved
37-39	3	Vendor OUI	00 00 00	No specific
40-55	16	Vendor PN	4D 50 4C 4F 32 30 2D 44 36 43 2D 43 33 44 54 31	MPLO20-D6C-B4T1

56-59	4	Vendor rev	41 30 20 20	A0
60-61	2	Wavelength	05 D2	1490nm
62	1	Reserved	00	Reserved
63	1	CC_BASE	Programmed by Factory	Check sum of bytes 0-62
64-65	2	Transceiver Options	10	page selection
			14	RX_SD, TX_Disable
66	1	BR, max	00	
67	1	BR, min	00	
68-83	16	Vendor SN	Programmed by Factory	Serial number provided by vendor (ASCII)
84-91	8	Date Code	“YYMMDDLL”	Vendor's manufacturing date code (ASCII)
92	1	Diagnostic Monitoring Type	68	Internal Calibrated; Received power measurement type: Average Power
93	1	Enhanced Options	E0	Optional Alarm/warning implemented; Soft TX_DISABLE, TX_FAULT implemented
94	1	Compliance	08	Revision Implemented
95	1	CC_EXT	Programmed by Factory	Check sum of bytes 64-94
96-127	32	Vendor Specific		Vendor Specific EEPROM
128-255	128	Reserved	00	Reserved

EEPROM A2h Alarm and Warning Thresholds (XGSPON/XGPON)

Address	Field Size(Byte)	Name of field	Hex Value	Description
00-01	2	Temp High Alarm	50 00	MSB at low address, +80°C
02-03	2	Temp Low Alarm	F6 00	MSB at low address, -10°C
04-05	2	Temp High Warning	46 00	MSB at low address, +70°C
06-07	2	Temp Low Warning	00 00	MSB at low address, 0°C
08-09	2	3.3V Voltage High Alarm	8C 9F	MSB at low address, 3.6V
10-11	2	3.3V Voltage Low Alarm	75 30	MSB at low address, 3.0V
12-13	2	3.3V Voltage High Warning	88 B8	MSB at low address, 3.5V
14-15	2	3.3V Voltage Low Warning	79 17	MSB at low address, 3.1V

16-17	2	Bias High Alarm	75 30	MSB at low address, 120mA
18-19	2	Bias Low Alarm	13 88	MSB at low address, 20mA
20-21	2	Bias High Warning	6B 6C	MSB at low address, 110mA
22-23	2	Bias Low Warning	18 6A	MSB at low address, 25mA
24-25	2	TX Power High Alarm	4D C1	MSB at low address, +6dBm
26-27	2	TX Power Low Alarm	18 97	MSB at low address, +1dBm
28-29	2	TX Power High Warning	3D C3	MSB at low address, +5dBm
30-31	2	TX Power Low Warning	1E F4	MSB at low address, +2dBm
32-33	2	RX Power High Alarm	13 94	MSB at low address, -3dBm
34-35	2	RX Power Low Alarm	00 0B	MSB at low address, -29.5dBm
36-37	2	RX Power High Warning	0C 5A	MSB at low address, -5dBm
38-39	2	RX Power Low Warning	00 12	MSB at low address, -27.5dBm
40-41	2	TOSA Temp High Alarm	3A 00	MSB at low address, 58°C
42-43	2	TOSA Temp Low Alarm	1E 00	MSB at low address, 30°C
44-45	2	TOSA Temp High Warning	38 00	MSB at low address, 56°C
46-47	2	TOSA Temp Low Warning	20 00	MSB at low address, 32°C
48-55	8	Reserved		Reserved

EEPROM B2h Alarm and Warning Thresholds (GPON)

Address	Field Size(Byte)	Name of field	Hex Value	Description
00-01	2	Temp High Alarm	50 00	MSB at low address, +80°C
02-03	2	Temp Low Alarm	F6 00	MSB at low address, -10°C
04-05	2	Temp High Warning	46 00	MSB at low address, +70°C
06-07	2	Temp Low Warning	00 00	MSB at low address, 0°C
08-09	2	3.3V Voltage High Alarm	8C 9F	MSB at low address, 3.6V
10-11	2	3.3V Voltage Low Alarm	75 30	MSB at low address, 3.0V
12-13	2	3.3V Voltage High Warning	88 B8	MSB at low address, 3.5V
14-15	2	3.3V Voltage Low Warning	79 17	MSB at low address, 3.1V
16-17	2	Bias High Alarm	61 A8	MSB at low address, 100mA
18-19	2	Bias Low Alarm	01 F4	MSB at low address, 2mA
20-21	2	Bias High Warning	57 E4	MSB at low address, 90mA
22-23	2	Bias Low Warning	02 EE	MSB at low address, 3mA
24-25	2	TX Power High Alarm	4D C1	MSB at low address, +6dBm

26-27	2	TX Power Low Alarm	15 EA	MSB at low address, +0.5dBm
28-29	2	TX Power High Warning	3D C3	MSB at low address, +5dBm
30-31	2	TX Power Low Warning	15 EA	MSB at low address, +1.5dBm
32-33	2	RX Power High Alarm	09 D0	MSB at low address, -6dBm
34-35	2	RX Power Low Alarm	00 0A	MSB at low address, -30dBm
36-37	2	RX Power High Warning	06 31	MSB at low address, -8dBm
38-39	2	RX Power Low Warning	00 10	MSB at low address, -28dBm
40-55	16	Reserved		Reserved

RSSI trigger/TX_Disable selection (Table A2h Byte 118)

Address	Bit	Name of Field	Description
118	7	RSSI Select	Writing "0" for XGSPON/XGPON RSSI Monitor; Writing "1" for GPON RSSI Monitor. Default power up value is "0".
118	6	RSSI/TX_Disable Select	When set to "0", PIN9 as TX_Disable input; When set to "1", PIN9 as RSSI input. Default power up value is "0".
118	5	XGSPON TX_Disable Selection	When set "0", PIN9 as the XGSPON/XGPON TX_Disable input. Default power up value is "0".
118	4	GPON TX_Disable Selection	When set "0", PIN9 as the GPON TX_Disable input. Default power up value is "0".

Product Security requirements

Items	Contents
Virus scanning	Don't contain malicious code or code vulnerabilities such as Trojans, viruses, worms, backdoors, etc.
Source code static scanning	Don't contain dead pointers, divide by 0, integer overflow, invalid shift operations, memory management, null pointer indirect references, boundary overflow checks, uninitialized variables, write constants, etc.
Source code security scanning	Don't contain memory leaks, out of bounds errors, arithmetic errors, suspicious code, logic errors, etc.

Package Outline

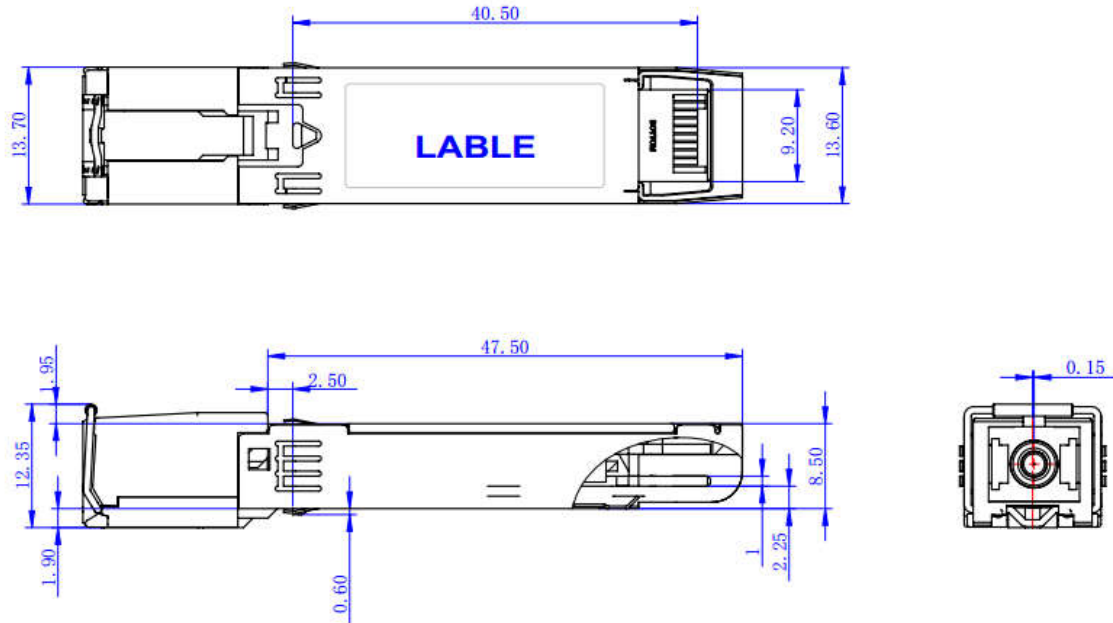

Figure8 Package Outline for MPLO20-D6C-B4T1

Ordering information

PART NO.	Specifications							
	Application	Rate (Gbps)	Tx (nm)	Po (dBm)	Rx (nm)	Sen (dBm)	Temp (°C)	DDM
MPLO20-D 6C-B4T1	XGSPON	TX:9.953/ RX:9.953	1577	2~5	1270	<-26 (10 ⁻³)	0~+70 °C	Y
	XGPON	TX:9.953/ RX:2.488				<-27.5 (10 ⁻⁴)		
	GPON	TX:2.488/ RX:1.244	1490	1.5~5	1310	<-28 (10 ⁻¹⁰)		