MQA4Z10-DMC-T1

Features

- ◆ Hot-pluggable QSFP+ form factor
- ◆ Supports 10.3125Gb/s bit rate per channel
- ◆ Maximum link length of 10km on G.652 SMF
- ◆ 4 channels 1310nm DFB laser and 4 channels PIN photo detector array
- ◆ Single MPO connector receptacle
- ◆ Case operating temperature range: 0 ~ +70°C
- ◆ Single 3.3V power supply
- ◆ Power dissipation: <3.5 W
- ◆ QSFP+ housing with enhanced EMI shielding

Applications

- ◆ Data center and Cloud services
- ◆ 40G Ethernet links
- ◆ Infiniband SDR/DDR/QDR interconnects
- ◆ OC-192 ,OTU1e ,OTU2 ,OTU2e and OTU3
- ◆ Servers, Switches, Storage and Host Card Adapters

Standards

- ◆ Compliant with QSFP+ MSA
- ◆ Compliant with IEEE 802.3ba
- ◆ Compliant with SFF-8436
- ◆ RoHS Compliant

1. General Description

MQA4Z10-DMC-T1 is a Four-Channel, Pluggable, Parallel, Fiber-Optic QSFP+ PSM4 for 40Gigabit Ethernet and Infiniband SDR/DDR/QDR applications. This transceiver is a high performance module for data communication and interconnect applications. It integrates four data lanes in each direction with 41.25Gbps bandwidth. Each lane can operate at 10.3125Gbps up to 10km over G.652 SMF. This module is designed to operate over single mode fiber systems using a nominal wavelength of 1310nm. The electrical interface uses a 38 contact edge type connector. The optical interface uses a 12 fiber MTP (MPO) connector.

2. Absolute Maximum Ratings

It has to be noted that the operation in excess of any individual absolute maximum ratings might cause permanent damage to this module.

Parameter	Symbol	Min	Max	Unit
Storage Temperature	Ts	-40	+85	°C
Operating Humidity	RH	0	85	%
Power Supply Voltage	Vcc	-0.5	3.6	V

3. Recommended Operating Environment

Recommended Operating Environment specifies parameters for which the electrical and optical characteristics hold unless otherwise noted.

Parameter	Symbol	Min	Typical	Max	Unit
Operating Case Temperature	Tcase	0	-	70	°C
Power Supply Voltage	Vcc	3.135	3.3	3.465	V
Power Supply Current	Icc	-		1100	mA
Data Rate, each channel	BR	10.3125±100ppm			Gbps
Transmission Distance on G.652 SMF	TD	0.002	-	10	km

4. Optical Characteristics

The following Optical characteristics are defined over the Recommended Operating Environment unless otherwise specified.

Parameter	Symbol	Min	Typical	Max	Unit	Notes
Transmitter Characteristics						
Center Wavelength	λ_c	1295	1310	1325	nm	
Average Launch Power, each lane	P_{AVG}	-6.5		1.5	dBm	
Optical Power OMA, each Lane	P_{OMA}	-5.2		2.0	dBm	1
Side Mode Suppression Ratio	SMSR	30			dB	
Optical Extinction Ratio	ER	3.5			dB	
Transmitter and Dispersion Penalty, each lane	TDP			3.2	dB	
Optical Return Loss Tolerance	ORL			12	dB	
Transmitter Reflectance	R_T			-12	dB	
Output Eye Mask coordinates: {X1, X2, X3, Y1, Y2, Y3}		{0.25,0.4,0.45,0.25,0.28,0.4}				2,3
Receiver Characteristics						
Receiver Wavelength	λ_{in}	1295	1310	1325	nm	
Damage Threshold, each lane	THd	3.3			dBm	4
Average Receive Power, each lane	RSENS	-12.6		1.5	dBm	
Receiver Sensitivity (OMA), each lane	P_{sen1}			-12.6	dBm	5
LOS	LOS Assert	LOSA	-30		dBm	
	LOS De-Assert	LOSD		-15	dBm	
	LOS Hysteresis	LOSH	0.5		dB	
Input Saturation Power (Overload)	Psat	0.5			dBm	
Receiver Reflectance	R_r			-12	dB	

Notes:

1. Even if the TDP < 1dB, the OMA min must exceed the minimum value specified here.
2. Compliant with IEEE 802.3ba.
3. Transmitter hit ratio 1E-12 hits/sample.

4. The receiver shall be able to tolerate, without damage, continuous exposure to a modulated optical input signal having this power level on one lane. The receiver does not have to operate correctly at this input power.
5. Receiver Sensitivity(OMA) measured with a PRBS 2³¹-1 test pattern, @10.3125Gb/s, BER<1E-12.

5. Electrical Characteristics

The following electrical characteristics are defined over the Recommended Operating Environment unless otherwise specified.

Parameter	Symbol	Min	Typical	Max	Unit	Notes
Supply Voltage	V _{CC}	3.135	3.3	3.465	V	
Supply Current	I _{CC}			1100	mA	
Transmitter						
Input differential impedance	Z _{IN}	90	100	110	Ω	
Differential data input swing	V _{in,pp}	200		800	mV _{PP}	1
Single ended input voltage tolerance	V _{inT}	-0.3		4.0	V	
Receiver						
Single ended output voltage tolerance	V _{outT}	-0.3		4.0	V	
Differential Output impedance	Z _{OUT}	90	100	110	Ω	
Differential data output swing	V _{out,pp}	300		850	mV _{PP}	2

Notes:

1. Differential data input swing is measured between TxnP and TxnN.
2. Differential data output swing is measured between RxnP and RxnN.

6. Digital Diagnostic Monitoring Information

Parameter	Units	Min	Max	Accuracy	Calibration	Note
Temperature	°C	0	+70	±3°C	Internal	
Voltage	V	3.135	3.465	±3%	Internal	
Bias Current	mA	0	70	±10%	Internal	1
TX Power	dBm	-6.5	1.5	±3dB	Internal	
RX Power	dBm	-12.6	1.5	±3dB	Internal	

Notes:

1. Accuracy of Measured Tx Bias Current is 10% of the actual Bias Current from the laser driver to the laser.

7. Pin Assignment

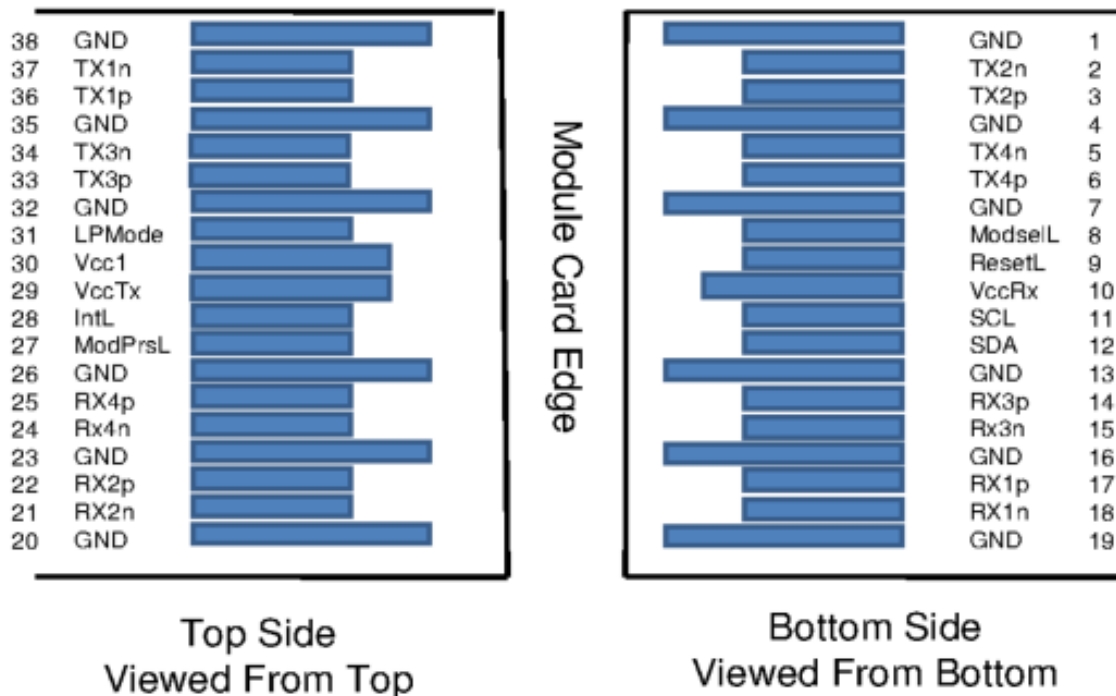

Figure 1 Pinout of Connector Block on Host Board

Table 1 PIN Definition

Pin	Symbol	Name/Description	Notes
1	GND	Transmitter Ground (Common with Receiver Ground)	1
2	Tx2n	Transmitter Inverted Data Input	
3	Tx2p	Transmitter Non-Inverted Data output	
4	GND	Transmitter Ground (Common with Receiver Ground)	1
5	Tx4n	Transmitter Inverted Data Input	
6	Tx4p	Transmitter Non-Inverted Data output	
7	GND	Transmitter Ground (Common with Receiver Ground)	1
8	ModSelL	Module Select	
9	ResetL	Module Reset	
10	VccRx	3.3V Power Supply Receiver	2
11	SCL	2-Wire serial Interface Clock	
12	SDA	2-Wire serial Interface Data	
13	GND	Transmitter Ground (Common with Receiver Ground)	
14	Rx3p	Receiver Non-Inverted Data Output	
15	Rx3n	Receiver Inverted Data Output	

16	GND	Transmitter Ground (Common with Receiver Ground)	1
17	Rx1p	Receiver Non-Inverted Data Output	
18	Rx1n	Receiver Inverted Data Output	
19	GND	Transmitter Ground (Common with Receiver Ground)	1
20	GND	Transmitter Ground (Common with Receiver Ground)	1
21	Rx2n	Receiver Inverted Data Output	
22	Rx2p	Receiver Non-Inverted Data Output	
23	GND	Transmitter Ground (Common with Receiver Ground)	1
24	Rx4n	Receiver Inverted Data Output	1
25	Rx4p	Receiver Non-Inverted Data Output	
26	GND	Transmitter Ground (Common with Receiver Ground)	1
27	ModPrsl	Module Present	
28	IntL	Interrupt	
29	VccTx	3.3V power supply transmitter	2
30	Vcc1	3.3V power supply	2
31	LPMODE	Low Power Mode, not connect	
32	GND	Transmitter Ground (Common with Receiver Ground)	1
33	Tx3p	Transmitter Non-Inverted Data Input	
34	Tx3n	Transmitter Inverted Data Output	
35	GND	Transmitter Ground (Common with Receiver Ground)	1
36	Tx1p	Transmitter Non-Inverted Data Input	
37	Tx1n	Transmitter Inverted Data Output	
38	GND	Transmitter Ground (Common with Receiver Ground)	1

Notes:

1. GND is the symbol for signal and supply (power) common for QSFP+ modules. All are common within the QSFP+ module and all module voltages are referenced to this potential unless otherwise noted. Connect these directly to the host board signal common ground plane.
2. VccRx, Vcc1 and VccTx are the receiving and transmission power suppliers and shall be applied concurrently. Recommended host board power supply filtering is shown below. Vcc Rx, Vcc1 and VccTx may be internally connected within the QSFP+ transceiver module in any combination. The connector pins are each rated for a maximum current of 500mA.

8. EEPROM Memory Map

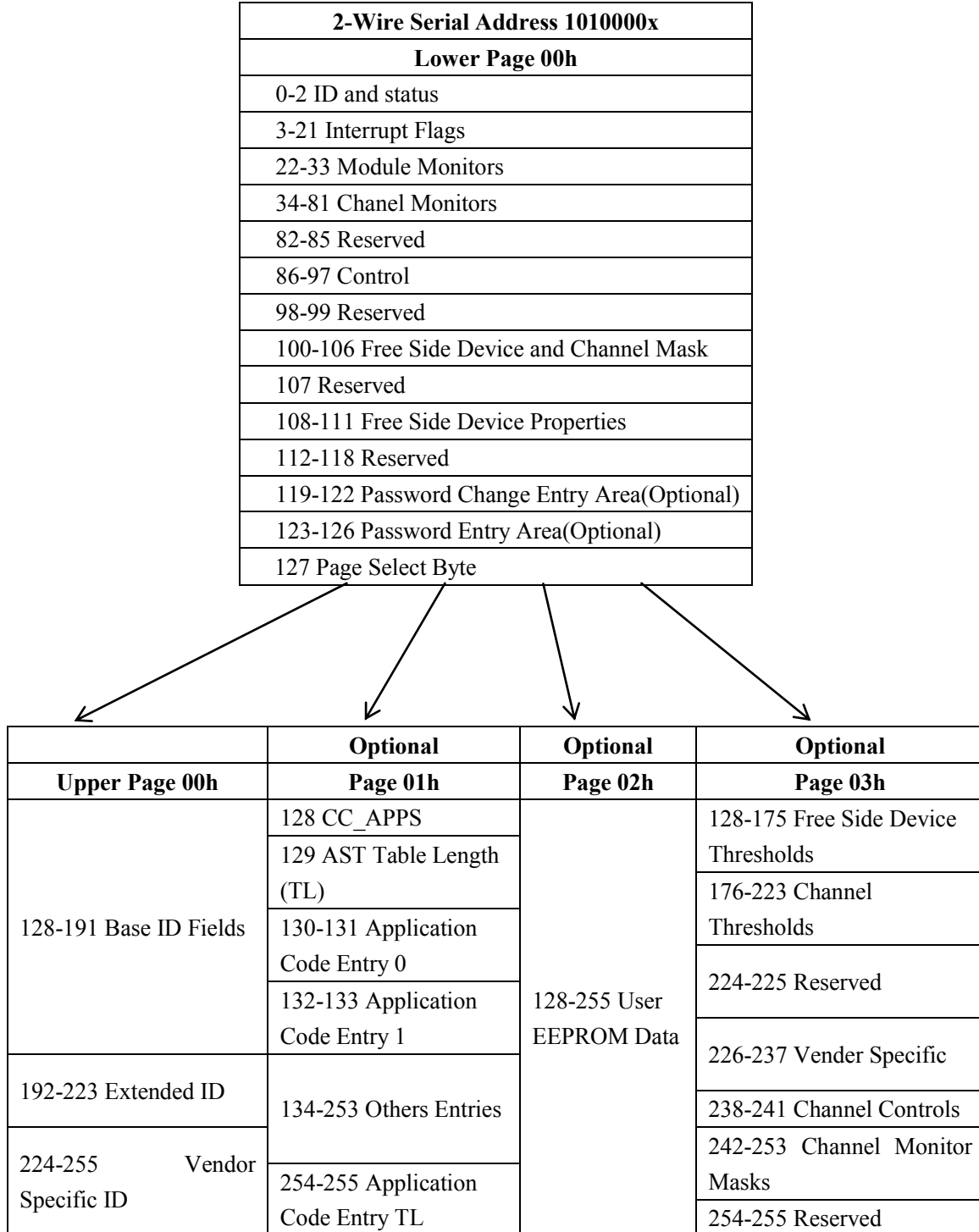

EEPROM Serial ID Memory Contents (2-Wire Serial Address A0h Upper Page 00h)

Address	Name of field	Hex	Description
BASE ID Fields			
128	Identifier	0D	QSFP+ transceiver
129	Ext. Identifier	C0	Extend Identifier of free side device
130	Connector Type	0C	MPO 1*12 (Multifiber Parallel Optic)
131-138	Specification Compliance	02 00 00 00 00 00 01 02	Code for electronic or optical compatibility
139	Encoding	03	Code for serial encoding algorithm
140	BR, nominal	69	Nominal bit rate per channel, units of 100Mbps
141	Extended Rate Select Compliance	02	Tags for extended rate select compliance
142	Length(SMF)	0A	Transceiver link length support for different fibers
143	Length(OM3 50um)	00	
144	Length(OM2 50um)	00	
145	Length(OM1 62.5um)	00	
146	Length(passive copper or active cable or OM4 50um))	00	
147	Device technology	40	Device technology
148-163	Vendor name	4D 45 4E 54 45 43 48 4F 50 54 4F 20 20 20 20 20	“MENTECHOPTO”(ASCII character)
164	Extended Module	07	SDR/DDR/QDR Infiniband
165-167	Vendor OUI	00 00 00	Free side device vendor IEEE company ID
168-183	Vendor PN	4D 51 42 34 5A 31 30 2D 44 4D 43 2D 54 31 20 20	“MQA4Z10-DMC-T1”(ASCII character)
184-185	Vendor rev	41 30	“A0”(ASCII character)
186-187	Wavelength or Copper Cable Attenuation	66 26	Nominal laser wavelength
188-189	Wavelength tolerance or Copper Cable Attenuation	25 1C	Guaranteed range of laser wavelength from nominal wavelength
190	Max case temp.	00	Maximum case temperature in degrees C.
191	CC_BASE	AD	Check code for base ID fields
Extended ID Fields			
192-195	Options	12 07 F0 60	Rate Select, TX Disable, TX Fault, LOS, Warning indicators

196-211	Vendor SN	xx.....xx	Serial number provided by vendor(ASCII)
212-219	Date Code	Data Code	Vendor's manufacturing date code
220	Diagnostic Monitoring Type	0C	Indicates which type of diagnostic monitoring is implemented
221	Enhanced Options	0C	Indicates which optional enhanced features are implemented in the free side device
222	BR, nominal	00	Nominal bit rate per channel, units of 250 Mbps.
223	CC-EXT	38	Check code for the Extended ID Fields
Vendor Specific ID Field			
224-255	Vendor Specific	00	Vendor specific EEPROM

Free Side Device and Channel Thresholds (2-Wire Serial Address A0h Page 03h)

Address	#Bytes	Name of field	Real Value	Unit	Hex
128-129	2	Temp High Alarm	80	°C	
130-131	2	Temp Low Alarm	-10	°C	
132-133	2	Temp High Warning	75	°C	
134-135	2	Temp Low Warning	-5	°C	
136-143	8	Reserved	Reserved		
144-145	2	Vcc High Alarm	3.7	V	
146-147	2	Vcc Low Alarm	2.9	V	
148-149	2	Vcc High Warning	3.6	V	
150-151	2	Vcc Low Warning	3.0	V	
152-159	8	Reserved	Reserved		
160-175	16	Vendor Specific			
176-177	2	RX Power High Alarm	2.5	dBm	
178-179	2	RX Power Low Alarm	-13.6	dBm	
180-181	2	RX Power High Warning	1.5	dBm	
182-183	2	RX Power Low Warning	-12.6	dBm	
184-185	2	TX Bias High Alarm	75	mA	
186-187	2	TX Bias Low Alarm	10	mA	
188-189	2	TX Bias High Warning	70	mA	
190-191	2	TX Bias Low Warning	15	mA	
192-193	2	TX Power High Alarm	2.5	dBm	
194-195	2	TX Power Low Alarm	-7.5	dBm	
196-197	2	TX Power High Warning	1.5	dBm	

198-199	2	TX Power Low Warning	-6.5	dBm	
200-207	8	Reserved	Reserved		
208-223	16	Vendor Specific			

9. Optical Module Block Diagram

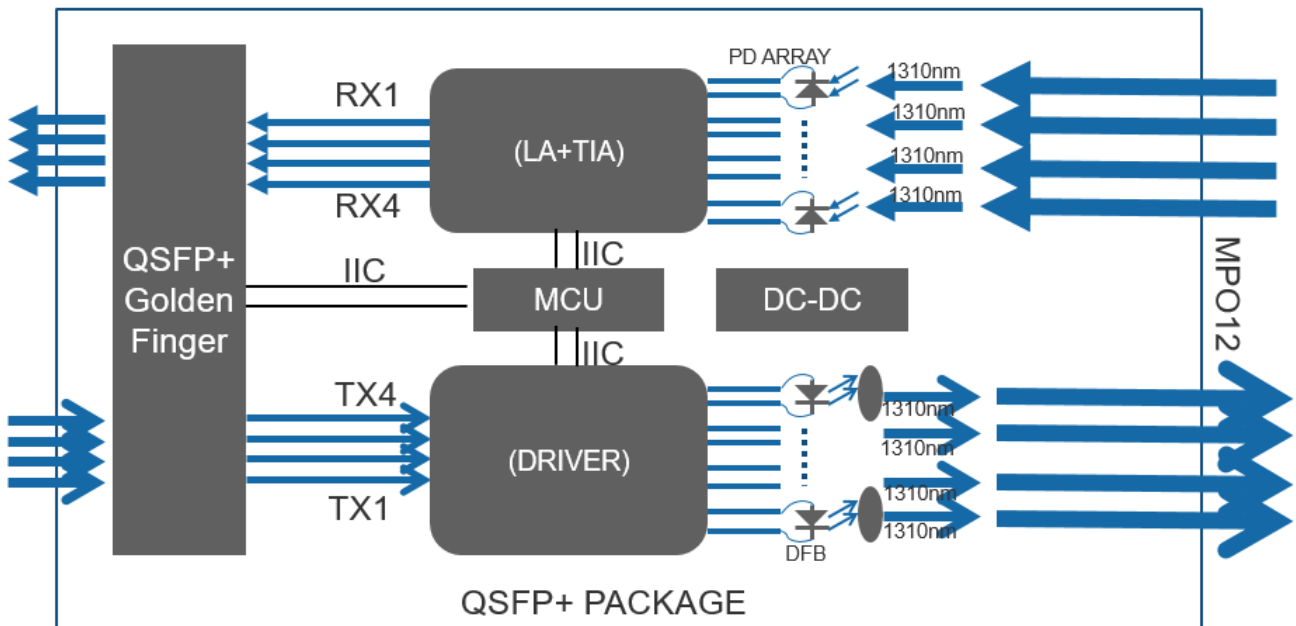

10. Mechanical Drawing

Dimensions are in millimeters. (Unit: mm)

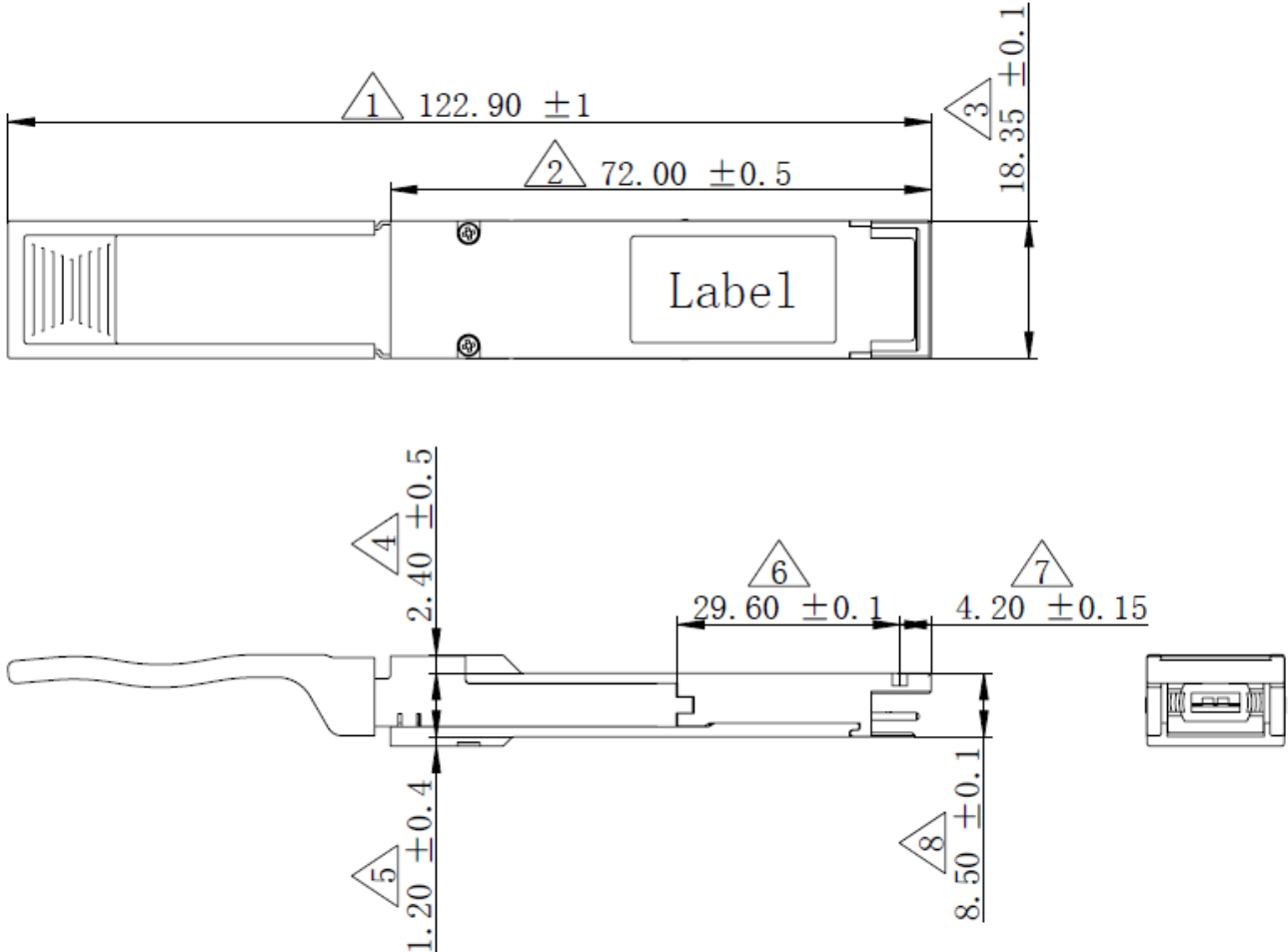

11. Ordering information

Part. No	Specifications								
	Pack	Rate (Gbps)	Tx (nm)	Po (dBm)	Sen (dBm) ¹	Temp (°C)	Reach (km) ²	Pull Tab Color	DDM
MQA4Z10-DMC-T1	QSFP+	41.2	1310	-6.5~1.5	<-12.6	0~+70	10	Blue	Y

*Note:

1. Measured with a PRBS 2³¹-1 test pattern, @10.3125Gb/s, BER<1E-12.
2. Transmission distance on G.652 SMF ≤ 10km.
3. More detail product selection and cable lengths, please contact MNC.